

Mounts and Accessories for equiP Series Explosion-Proof and Corrosion-Proof Cameras

Specialised mounts and accessories are now available for Honeywell's new line of explosion-proof and corrosion-proof cameras. All of the mounts are made of AISI-grade electropolished 316L stainless steel for maximum corrosion resistance and strength at high temperatures.



HCPWM



HCPPMA



HCPCMA



HCPPRM



HCPPRMJ



HCPWK



HCPWSK



HEPWS

ACCESSORIES	DESCRIPTION	EXPLOSION-PROOF CAMERA	CORROSION-PROOF CAMERA
HCPWM	Wall Mount Bracket with Joint	✓	✓
HCPPMA	Pole Mount Adapter	✓	✓
HCPCMA	Corner Mount Adapter	✓	✓
HCPPRM	Parapet Mount Bracket	✓	
HCPPRMJ	Parapet Mount Joint	✓	
HCPWK	Wiper Kit		✓
HCPWSK	Washer System Kit, 5 L		✓
HEPWS	Washer System Kit, 10 L	✓	

Mounts and Accessories

DIMENSIONS

HCPWM Wall Mount Bracket with Joint

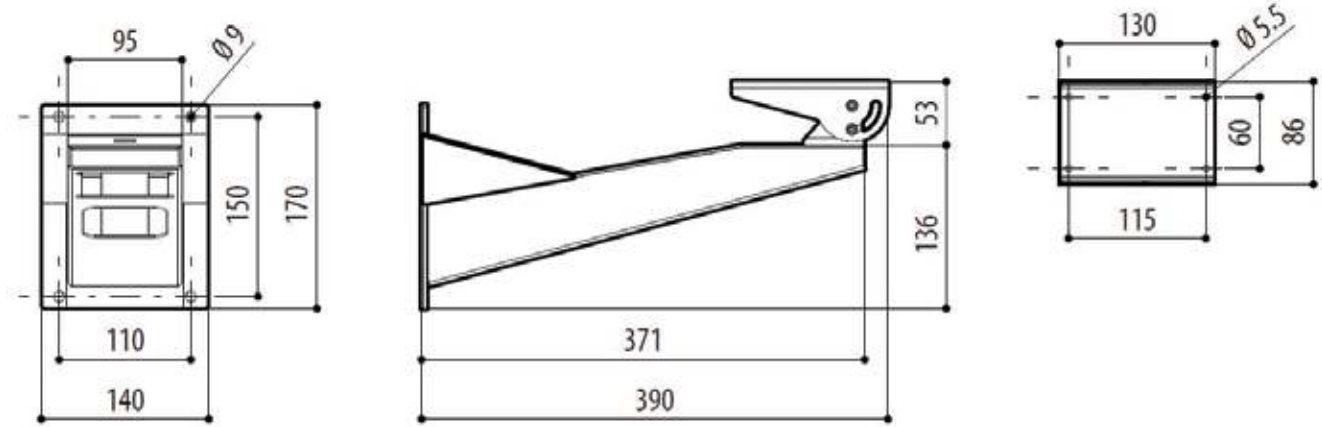

HCPPMA Pole Mount Adapter

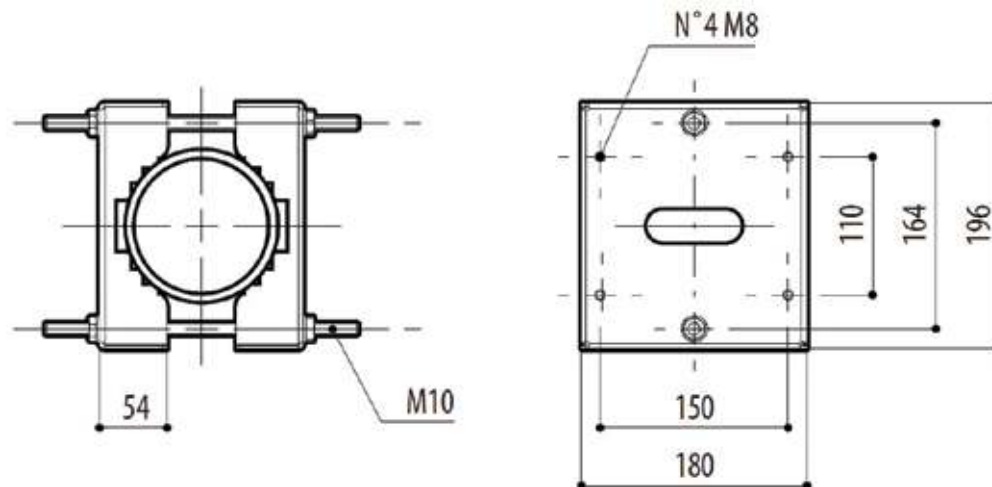

HPCPCMA Corner Mount Adapter

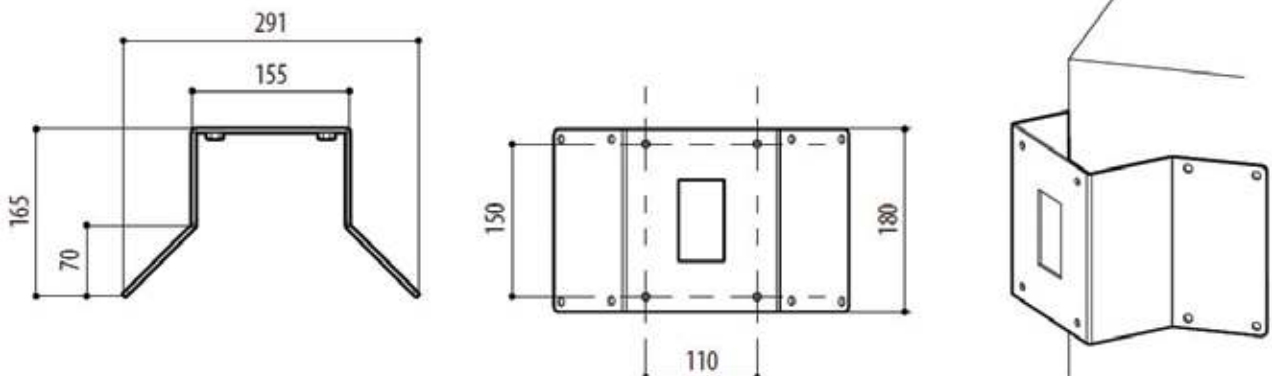

Mounts and Accessories

DIMENSIONS

HCPPRM Parapet Mount Bracket

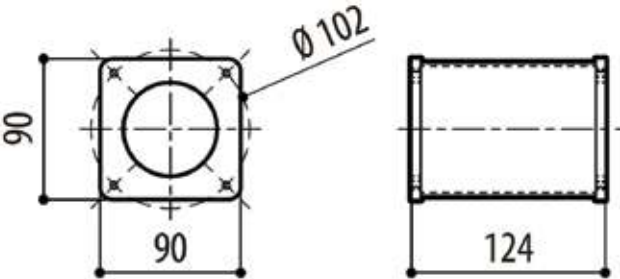

HCPPRMJ Parapet Mount Joint

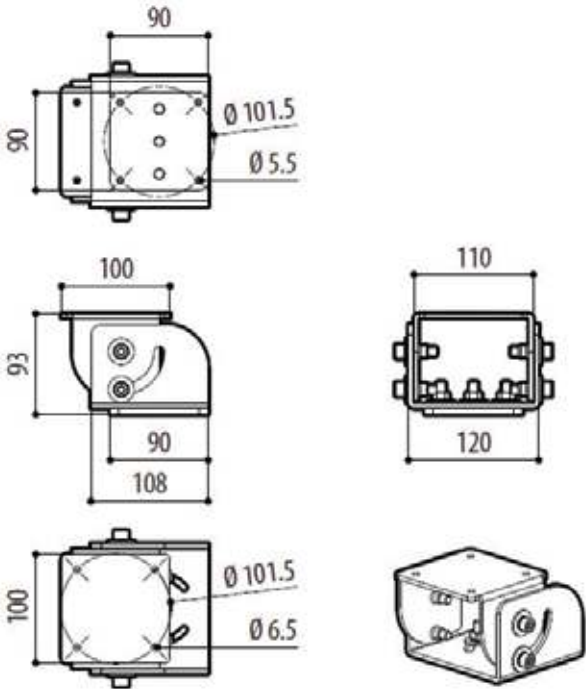

HCPWK Wiper Kit

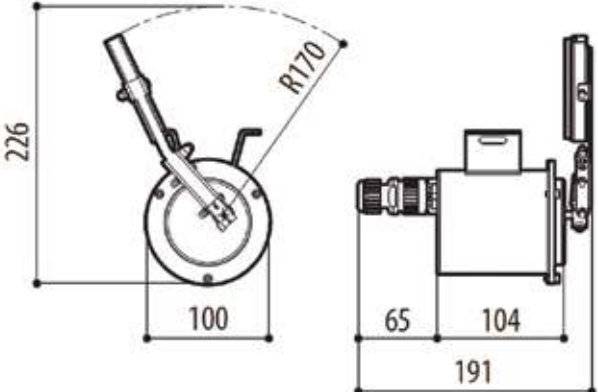

Mounts and Accessories

DIMENSIONS

HCPWSK Washer Pump

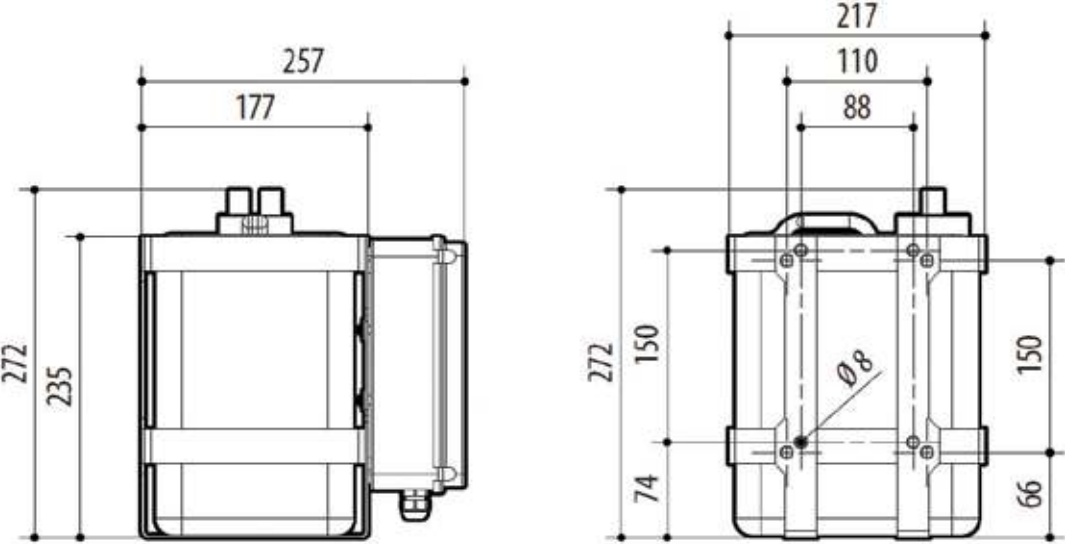

HEPWS Washer Pump

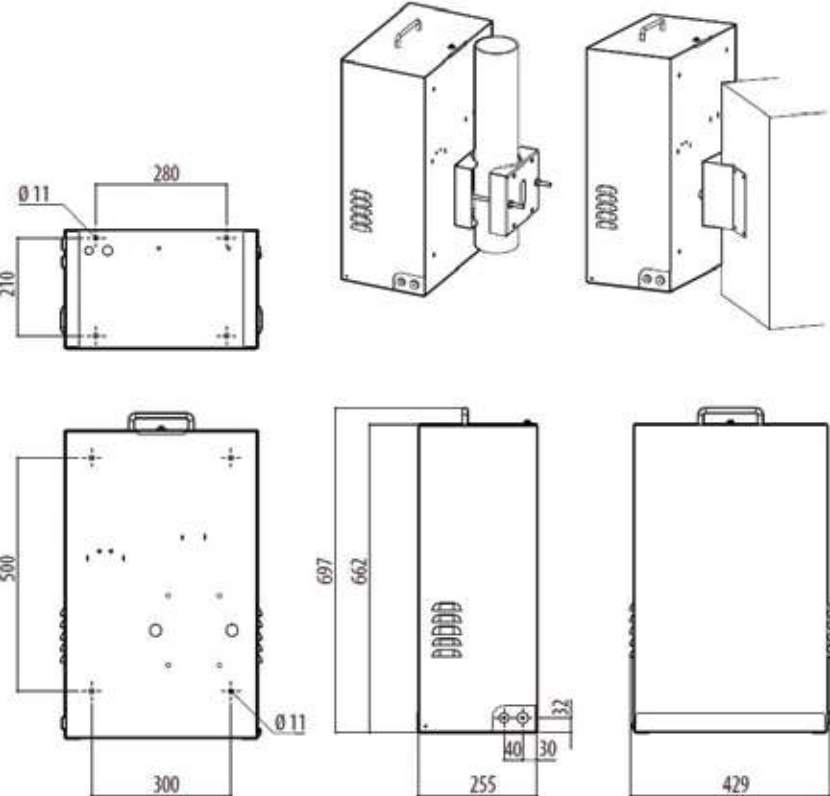

Mounts and Accessories

SPECIFICATIONS

MODEL	LOAD RATING	UNIT WEIGHT	COMMENTS
HCPWM	45 kg	2.5 kg	Suitable for use with HCPPMA and CPCMA
HCPPMA	50 kg	3.3 kg	Suitable for use with HCPWM
HCPCMA	50 kg	1.2 kg	Suitable for use with HCPWM
HCPPRM	70 kg	0.9 kg	Suitable for use with HCPPRMJ
HCPPRMJ	40 kg	2.0 kg	Suitable for use with HCPPRM
HCPWK	-	1.7 kg	Connector 3+1 poles, easy wiring harness 24 VAC, 290 mA max, 50/60 Hz input, 7 W max consumption
HCPWSK	-	3.8 kg	Delivery head up to 5 m 24/120/230 VAC input, 44 W max consumption
HEPWS	-	18 kg	Delivery head up to 20 m 24 VAC/VDC input, 5 W max consumption

CERTIFICATIONS

MODEL	DESCRIPTION	CERTIFICATIONS
HCPWK	Wiper Kit	EN 50130-4, EN 50581, EN 55032, EN 60950-1, EN 60950-22
HCPWSK	Washer System Kit, 5 L	EN 50130-4, EN 50581, EN 55032, EN 60950-1, EN 60950-22, EN 61000-3-2, EN 61000-3-3
HEPWS	Washer System Kit, 10 L	EN 60079-0, EN 60079-1, EN 60079-31

ORDERING

MODEL	DESCRIPTION	COMPATIBLE CAMERAS
HCPWM	Wall Mount Bracket with Joint	HEPB302W01A04, HEPB302W01A10, HCPB302
HCPPMA	Pole Mount Adapter	HEPB302W01A04, HEPB302W01A10, HCPB302
HCPCMA	Corner Mount Adapter	HEPB302W01A04, HEPB302W01A10, HCPB302
HCPPRM	Parapet Mount Bracket	HEPB302W01A04, HEPB302W01A10
HCPPRMJ	Parapet Mount Joint	HEPB302W01A04, HEPB302W01A10
HCPWK	Wiper Kit	HCPB302
HCPWSK	Washer System Kit, 5 L	HCPB302
HEPWS	Washer System Kit, 10 L	HEPB302W01A04, HEPB302W01A10

NOTE: Honeywell reserves the right, without notification, to make changes in product design or specifications.

For additional information, please visit

www.honeywell.com/security/uk

Honeywell Security & Fire

Aston Fields Road
Whitehouse Industrial Estate
Runcorn
Cheshire
WA7 3DL
United Kingdom
Tel: +44 (0)8448 000 235
www.honeywell.com

Honeywell reserves the right, without notification, to make changes in product design or specifications.

HSFV-MNTS_ACC-01-UK(0517)DS-E
May 2017
© 2017 Honeywell International Inc.

Honeywell