

Operating Instructions

Ceiling Mount Bracket

Model No. **WV-Q160C**
WV-Q160S



Before attempting to connect or operate this product, please read these instructions carefully and save this manual for future use.

The model number is abbreviated in some descriptions in this manual.

Ns0817-0 PGQX2212ZA Printed in China

Preface

This ceiling mount bracket is exclusively designed to mount the network camera. Refer to the catalog or the installation guide of the camera for supported cameras.

- WV-Q160C: Clear dome cover
- WV-Q160S: Smoked dome cover (approx. 50 % of transmittance)

Precautions

- **Use only the specified camera.**
Failure to observe this may cause a fall of an inappropriate camera resulting in injury or accidents. Refer to the catalog or the installation guide of the camera for supported cameras
- **Avoid installing this bracket in the locations where salt damage occurs or corrosive gas is produced.**
Otherwise, the mounting portions will deteriorate and accidents such as a fall of the camera may occur.
- **Refer installation work to the dealer.**
Installation work requires technique and experience. Failure to observe this may cause fire, electric shock, injury, or damage to the product. Be sure to consult the dealer.
- **Do not install this product in locations subject to vibration.**
Loosening of mounting screws or bolts may cause a fall of the product resulting in injury or accidents.
- **Install this product in a location high enough to avoid people and objects from bumping the product.**
Failure to observe this may cause injury.
- **The measures of protection against a fall of the camera shall be taken.**
Failure to observe this may cause a drop resulting in injury. Be sure to install this bracket-specific safety wire.
- **Periodic inspections shall be conducted.**
Rust on the metal parts or screws may cause a fall of the product resulting in injury. Consult the dealer for the inspections.

Precaution for installation

This product is designed to be used indoors. This product is not operable outdoors. In order to prevent injury, the product must be securely mounted to a ceiling according to Installation Guide.

- Make sure that the installation area is strong enough to hold the total weight of the camera assembly (approx. 1.4 kg {3.1 lbs.}) before installation.
- The screws that secure the ceiling mount bracket (provided with the camera) in the ceiling are not supplied. Prepare them according to the material and strength of the area where the product is to be installed. In this case, wood screws and nails should not be used.
- Do not place this product in the following places.
 - Locations where a chemical agent is used such as a swimming pool
 - Locations subject to moisture or oil smoke such as a kitchen
 - Locations that have a specific environment that is subject to an inflammable atmosphere or solvents
 - Locations where a radiation, an X-ray, a strong radio wave or a strong magnetic field is generated
 - Locations near coasts directly subjected to sea breezes, or locations subject to corrosive gases such as from hot springs, volcanic regions, etc.
 - Locations where the temperature is not within $-10\text{ }^{\circ}\text{C}$ - $+50\text{ }^{\circ}\text{C}$ { $14\text{ }^{\circ}\text{F}$ - $122\text{ }^{\circ}\text{F}$ }.
 - Locations subject to vibrations, such as on vehicles, marine vessels, or above product lines (This product is not designed for on-vehicle use.)
 - Locations where it may get wet from rain or water splash (including under the eaves, etc.)
 - Locations subject to moisture or dust
 - Locations subject to condensation as the result of severe changes in temperature (In case of installing the product in such locations, the front cover may become foggy or condensation may be caused on the cover.)
- The screws and bolts must be tightened with an appropriate tightening torque according to the material and strength of the installation area. After tightening the screws or bolts, perform visual check to ensure tightening is enough and there is no backlash.
- The pull-out strength of the installation area shall be 196 N {44 lbf} or more per 1 screw.

Parts and functions

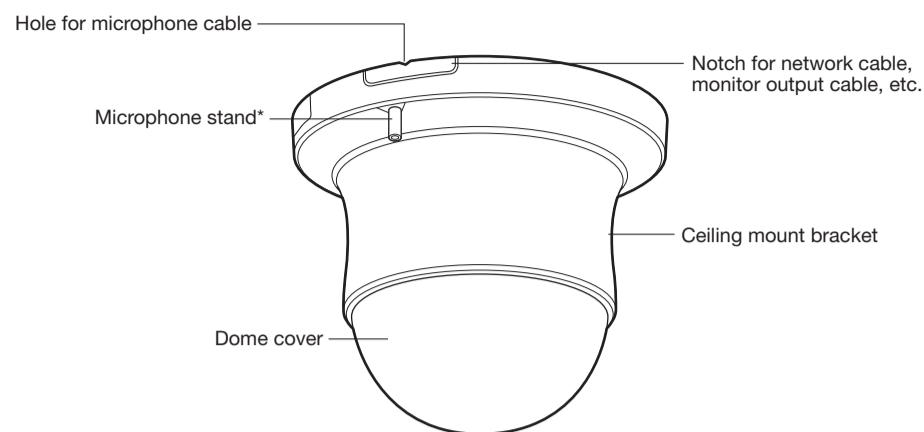

Note:

- Remove the notch with a nipper.
- If a tiepin type microphone is used, mount the microphone on the rubber-made microphone stand. Unless the microphone is used, cut the rubber with a nipper or conduct another treatment.

Important: In order to avoid injury and to protect the cable, file the edge of the notch.

Installations

Be sure to read "Precautions" before installation. The Installation Guide of the network camera shall be read as well.

1. Install the inner cover.

Slide the covers located on the both lateral sides of the camera and put the inner cover on the camera until the hooks inside the inner cover are held in the holes of the camera (until a click is heard).

Important: Put the inner cover down on the camera until the outside cover of the camera cannot be seen from the opening (from which the camera lens is visible) of the inner cover. If this integration is not successfully performed, the inner cover may be removed or the hidden part at the top of the screen may become larger in the WIDE mode.

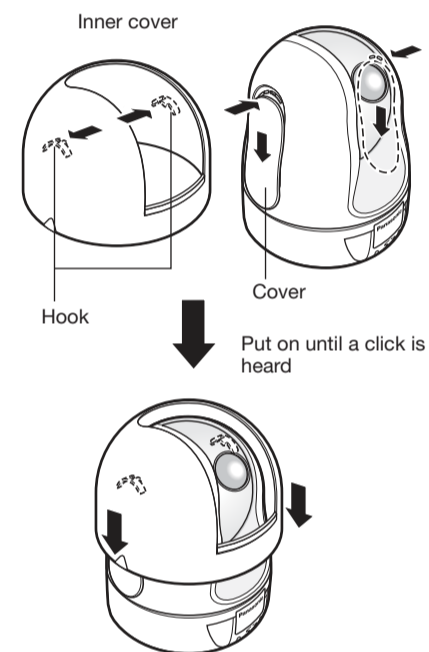

How to remove the inner cover

Press the inner cover from the front and rear sides inward (at the same vertical position as the hooks) to bend the cover and remove the cover from the camera.

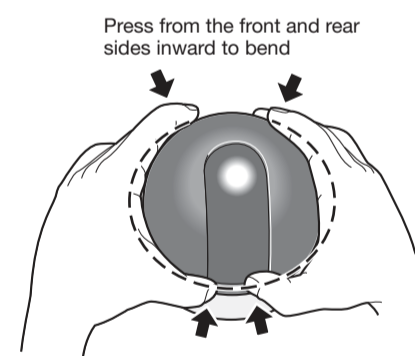

2. Mount the camera.

The camera shall be mounted on the camera mounting bracket (supplied with the camera) after mounting this bracket on a ceiling. For further information, refer to the Installation Guide of the network camera.

