

# equiP Series Explosion-Proof PTZ Cameras Mounts and Accessories

HEPZWM/HEPZPMA/HEPZCMA/HEPZPRM/  
HEPZA04/HEPZA10/HEPZT04/  
HEPZT10/HEPWS

You can install Honeywell's new equiP Series Explosion-Proof PTZ cameras HEPZ302W0 virtually anywhere with our new range of wall, ceiling, pole, and parapet mounting accessories. Other accessories for the HEPZ302W0 Explosion-Proof PTZ include a 10L washer system for cleaning the lens window and armored cables and cable tails to suit all types of corrosive, wet, dusty, or otherwise hazardous environments.

Designed for fast, easy installation, each accessory is constructed of AISI-grade 316L electropolished stainless steel for maximum strength, protection and corrosion resistance.

- The **HEPZWM wall mount bracket** can be installed on any interior or exterior wall, and is compatible with the HEPZPMA pole mount adapter and HEPZCMA corner mount adapter.
- The **HEPZPMA pole mount adapter** is suitable for use on poles between 110–150 mm (4.3 and 5.9 inches) in diameter. It can be used on its own or in conjunction with the HEPZWM wall mount bracket.
- The **HEPZCMA corner mount adapter** lets you install cameras securely on any outside corner. It can be used on its own or in conjunction with the HEPZWM wall mount bracket.
- The **HEPZPRM parapet/ceiling mount bracket** lets you install cameras securely to a wide variety of flat, horizontal surfaces, providing your surveillance setup with additional flexibility.
- The **HEPWS washer system** keeps the lens window of the camera clean by spraying a stream of water at regular intervals or manually with a remote command.
- The **HEPZA04/HEPZA10 armored cable** with barrier cable gland secures the cable and cable connections from tampering and wet/humid environments (ATEX/IECEX certified).
- The **HEPZT04/HEPZT10 cable tail** with conduit cable gland secures the cable and cable connections from tampering and web/humid environments (UL certified).



HEPWS



HEPZPMA



HEPZWM



HEPZPRM



HEPZCMA



HEPZA04/HEPZA10



HEPZT04/HEPZT10

## FEATURES AND BENEFITS

- Fast, easy installation
- Simple, modular design
- AISI 316L stainless steel construction
- Suitable for indoor or outdoor applications
- Can support loads between 88 and 110 lb (40–50 kg)
- Corrosion-resistant

# equiP Series Mounting Accessories

## DIMENSIONS

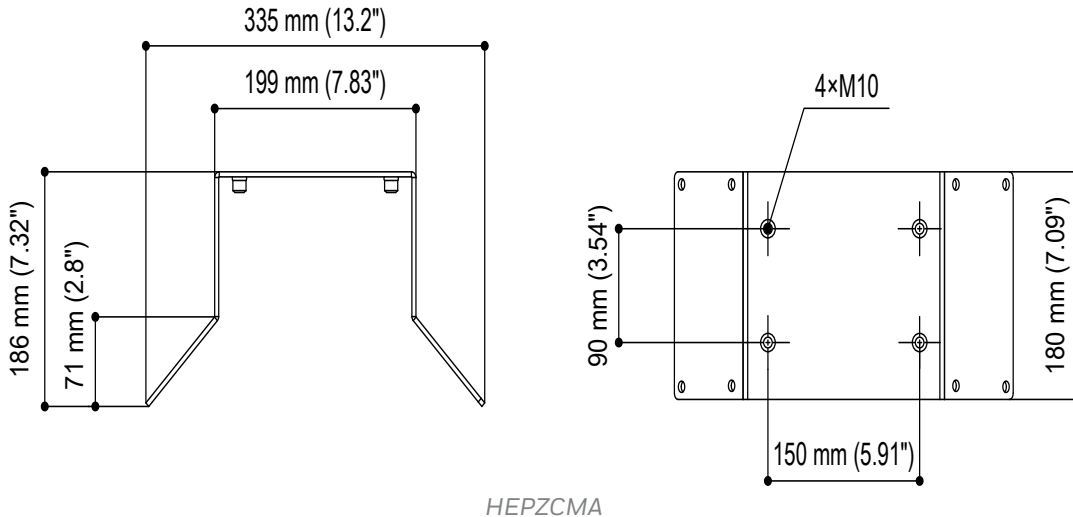
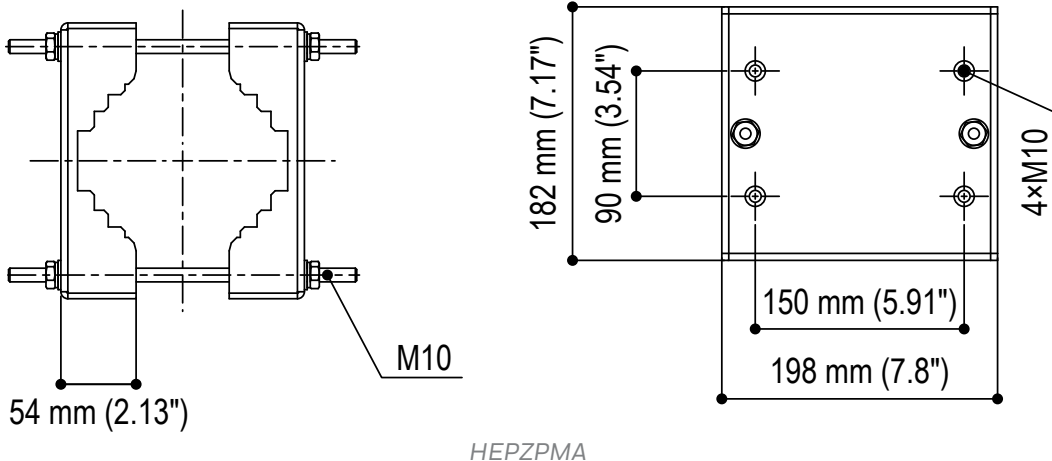
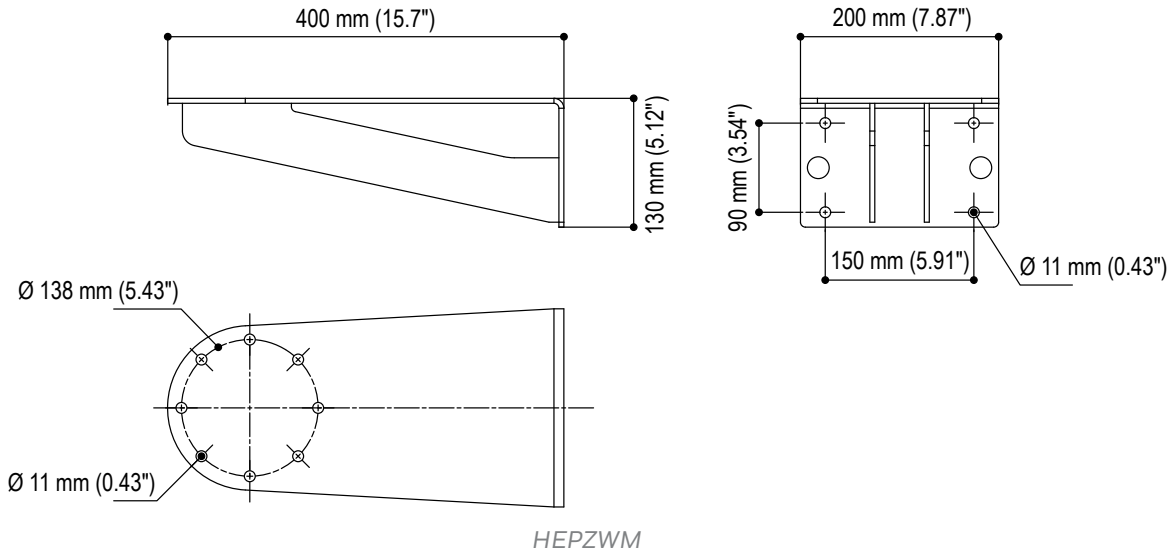

# equip Series Mounting Accessories

## DIMENSIONS

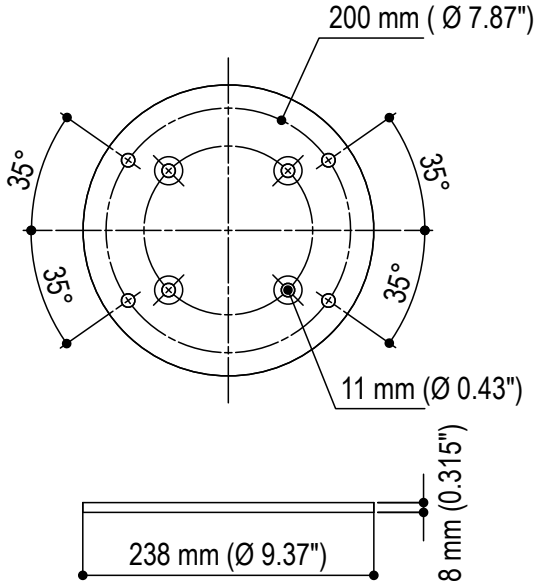

HEPZPRM

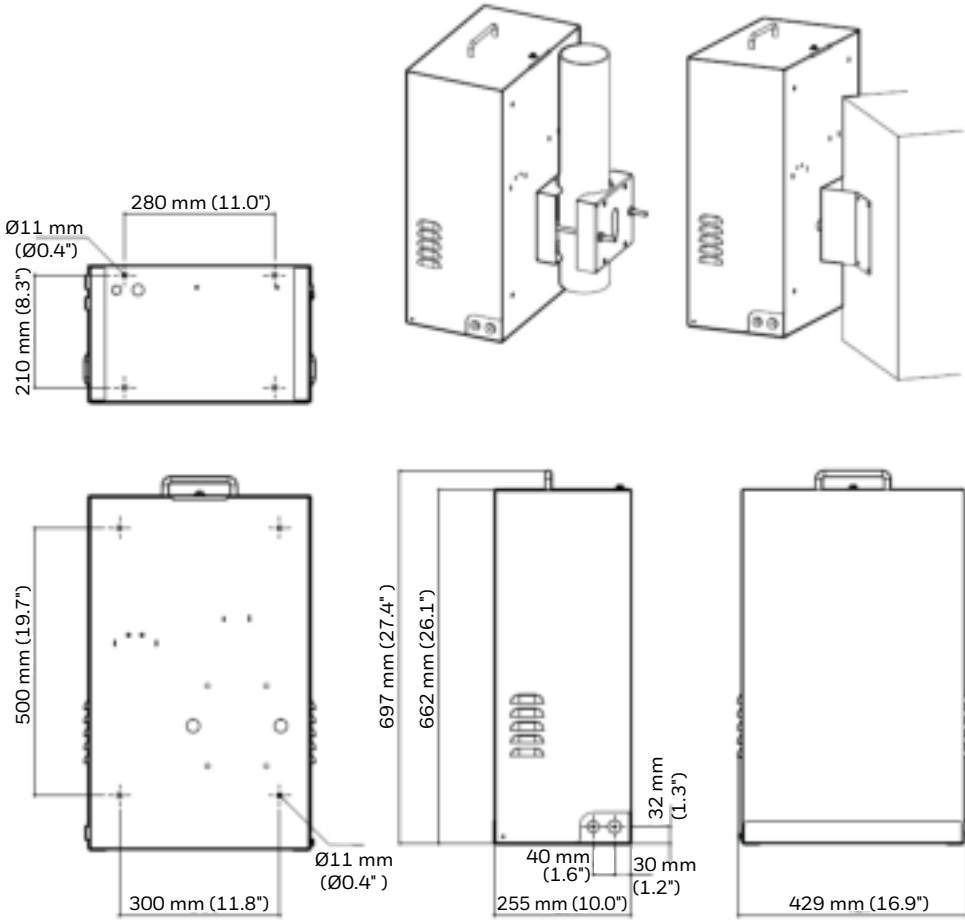

HEPWS

# equiP Series Mounting Accessories

## SPECIFICATIONS

MODEL	LOAD RATING	UNIT WEIGHT	DIMENSIONS	COMMENTS
HEPZWM	40 kg (88 lb)	5.4 kg (11.9 lb.)	400 × 130 mm (15.7 × 5.12 in.)	Compatible with HEPZPMA, HEPZCMA
HEPZPMA	50 kg (110 lb)	4.1 kg (9.0 lb.)	198 × 182 mm (7.8 × 7.17 in.)	Compatible with HEPZWM
HEPZCMA	50 kg (110 lb)	3.7 kg (8.2 lb.)	335 × 186 mm (13.2 × 7.32 in.)	Compatible with HEPZWM
HEPZPRM	40 kg (88 lb)	2.8 kg (6.2 lb.)	Ø 238 mm (9.37 in.)	N/A
HEPWS	N/A	18 kg (39.7 lb.)	429 × 662 × 255 mm (16.9 × 26.1 × 10.0 in.)	Delivery head up to 66 ft (20 m), 24 VAC/VDC input, 5 W max consumption
HEPZA04	N/A	1.9 kg (4.2 lb.)	500 × 500 × 200 mm (19.7 × 19.7 × 7.9 in.)	N/A
HEPZA10	N/A	5.0 kg (11.0 lb.)	500 × 500 × 200 mm (19.7 × 19.7 × 7.9 in.)	N/A
HEPZT04	N/A	1.5 kg (3.3 lb.)	13.0 × 10.9 × 2.0 in. (330 × 277 × 50 mm)	N/A
HEPZT10	N/A	2.9 kg (6.4 lb.)	330 × 277 × 50 mm (13.0 × 10.9 × 2.0 in.)	N/A

## ORDERING

MODEL	DESCRIPTION
HEPZWM	Wall Mount Bracket, AISI 316L stainless steel
HEPZPMA	Pole Mount Adapter, AISI 316L stainless steel
HEPZCMA	Corner Mount Adapter, AISI 316L stainless steel
HEPZPRM	Parapet/Ceiling Mount Adapter, AISI 316L stainless steel
HEPWS	Washer System Kit, with ATEX-certified solenoid valve, delivery head up to 20 m (66 ft), 24 VAC/VDC
HEPZA04	4 m Armored Cable with Barrier Cable Gland, ATEX/IECEX
HEPZA10	10 m Armored Cable with Barrier Cable Gland, ATEX/IECEX
HEPZT04	4 m Cable Tail with Conduit Cable Gland 3/4", UL
HEPZT10	10 m Cable Tail with Conduit Cable Gland 3/4", UL

### For more information

[www.honeywell.com/security/uk](http://www.honeywell.com/security/uk)

### Honeywell Security and Fire

Aston Fields Road  
Whitehouse Industrial Estate  
Runcorn  
Cheshire WA7 3DL  
Tel: 08448 000 235  
[www.honeywell.com](http://www.honeywell.com)

NOTE: Honeywell reserves the right, without notification, to make changes in product design or specifications.

HSFV-HEPZMTAC-01-UK(0917)DS-E  
September 2017  
© 2017 Honeywell International Inc.

**Honeywell**